

MURO DI SOSTEGNO V300

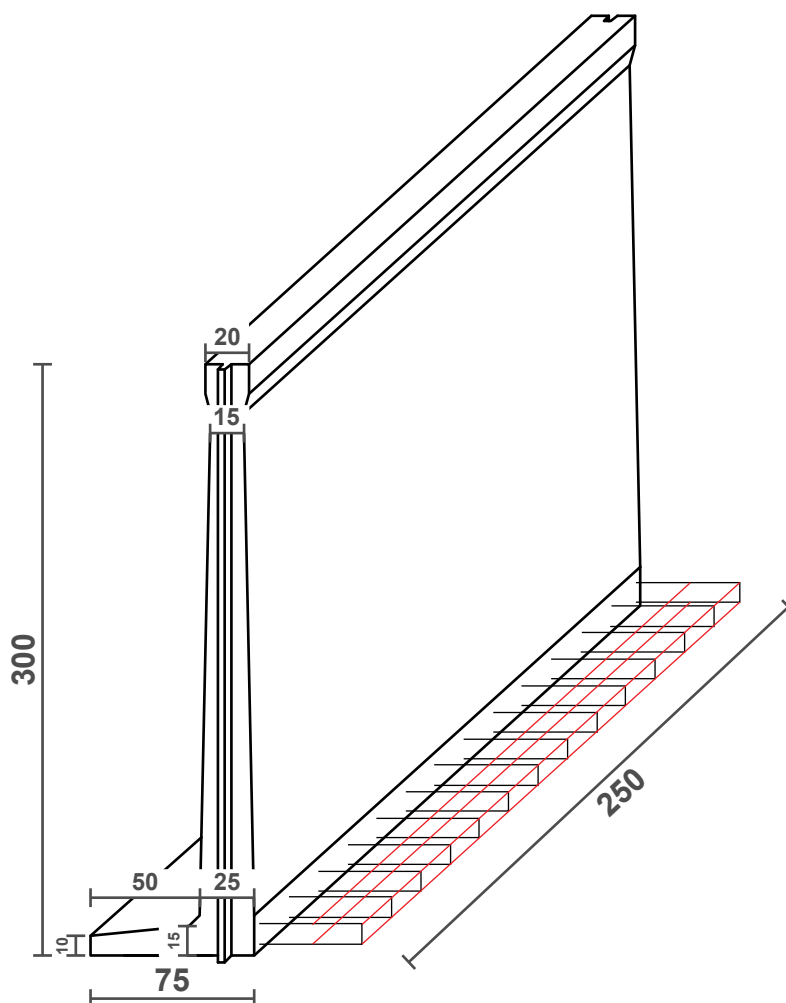

Dimensione elemento
0,75x2,50m H.3,00m

Peso elemento
37 q.li